

PRESS BRAKE TOOLS FACTORY CATALOGUE

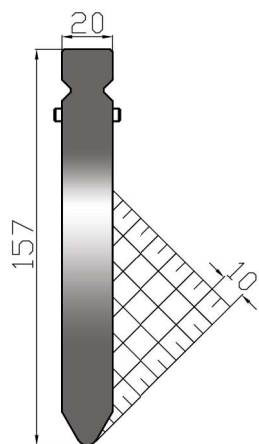

UST 157 S / 60° R4,0



UST 157 X / 28° R1,0

BIU-011/500

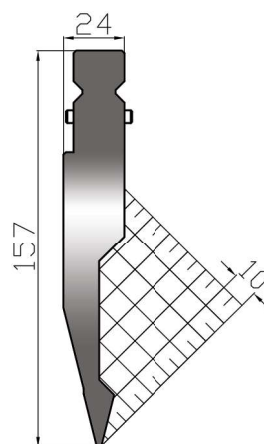

altezza height mm	angolo degree	raggio radius	acciaio steel	max kN/mt
157,0	60°	4,0	42CM4 T HRC 52+58	1300
lunghezze - lengths			mm 500 fraz C250 - L550(1A)	

altezza height mm	angolo degree	raggio radius	acciaio steel	max kN/mt
157,0	28°	1,0	42CM4 T HRC 52+58	600
lunghezze - lengths			mm 500 fraz C250 - L550(1A)	

UST 176 SP / 28° R1,0

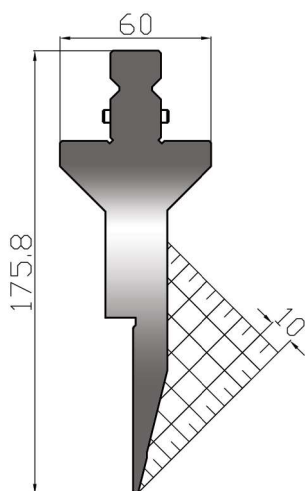

UST 157 D / 86° R1,0

BIU-012/500

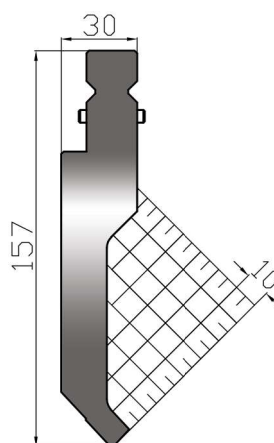

altezza height mm	angolo degree	raggio radius	acciaio steel	max kN/mt
175,8	28°	1,0	42CM4 T HRC 52+58	400
lunghezze - lengths			mm 500 fraz C250 - L550(1A)	

altezza height mm	angolo degree	raggio radius	acciaio steel	max kN/mt
157,0	86°	1,0	42CM4 T HRC 52+58	800
lunghezze - lengths			mm 500 fraz C250 - L550(1A)	

serie UST®

STANDARD TOOLS

UST 157 C / 60° R1,0

UST 157 C / 86° R1,0

BIU-013/500

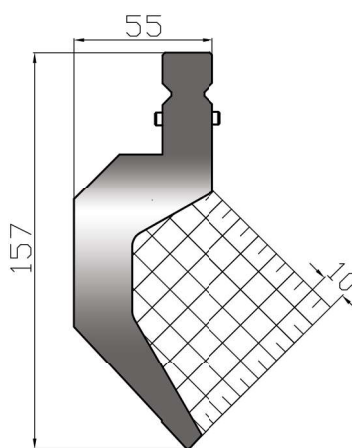
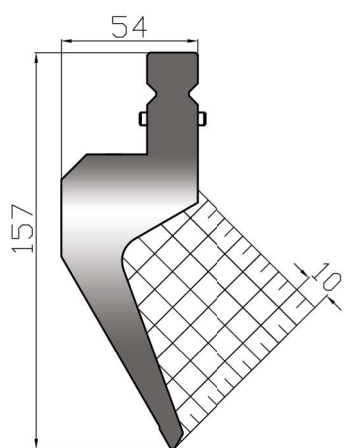

altezza height mm	angolo degree	raggio radius	acciaio steel	max kN/mt
157,0	60°	1,0	42CM4 T HRC 52+58	700
lunghezze - lengths			mm 500 fraz C250 - L550(1A)	

altezza height mm	angolo degree	raggio radius	acciaio steel	max kN/mt
157,0	86°	1,0	42CM4 T HRC 52+58	800
lunghezze - lengths			mm 500 fraz C250 - L550(1A)	

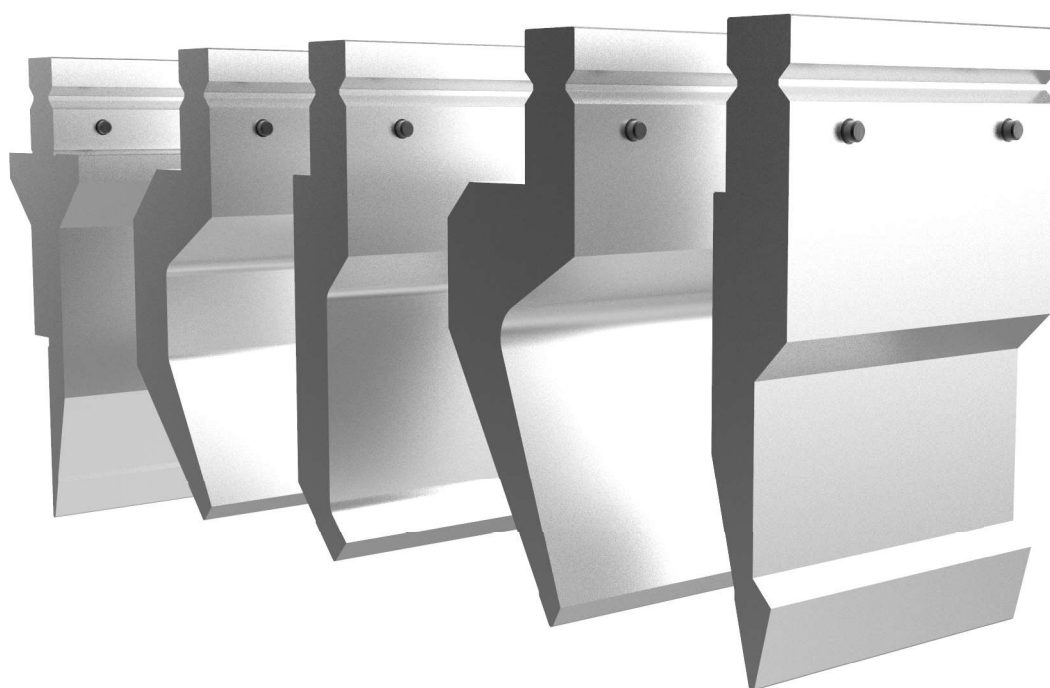

serie UST®

STANDARD TOOLS

UST 195 S / 26° R0,8

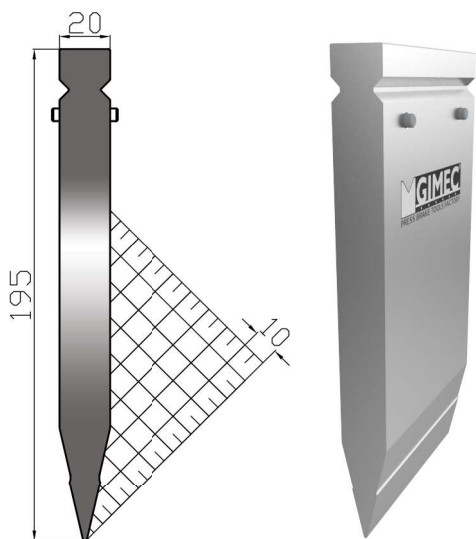

UST 195 S / 28° R3,0

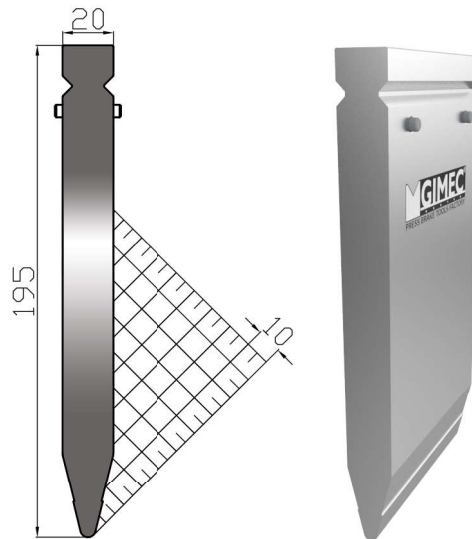

altezza height mm	angolo degree	raggio radius	acciaio steel	max kN/mt
195,0	26°	0,8	42CM4 T HRC 52+58	1000
lunghezze - lengths		mm 500 - fraz P 550		

altezza height mm	angolo degree	raggio radius	acciaio steel	max kN/mt
195,0	28°	3,0	42CM4 T HRC 52+58	1000
lunghezze - lengths		mm 500 - fraz P 550		

UST 195 X / 28° R1,0

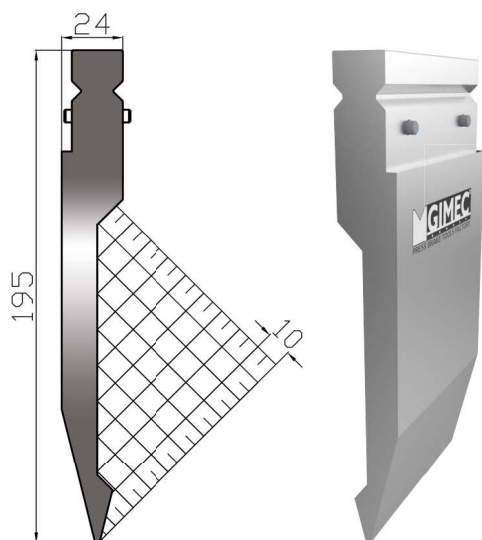

altezza height mm	angolo degree	raggio radius	acciaio steel	max kN/mt
195,0	28°	1,0	42CM4 T HRC 52+58	800
lunghezze - lengths		mm 500 - fraz P 550		



serie UST®

STANDARD TOOLS

UST 195 D / 86° R0,6

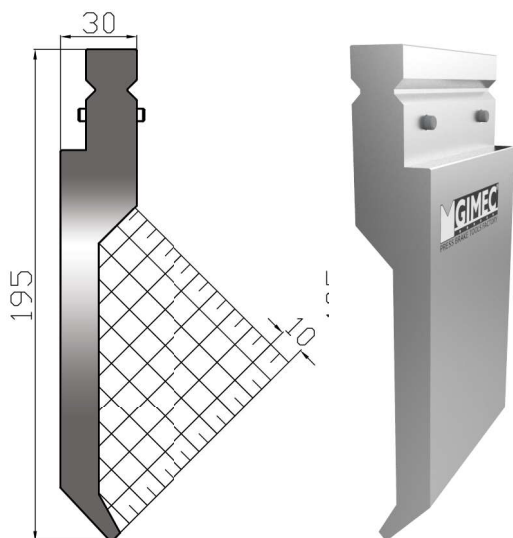

altezza height mm	angolo degree	raggio radius	acciaio steel	max kN/mt
195,0	86°	0,6	42CM4 T HRC 52+58	300
lunghezze - lengths		mm 500 - fraz P 550		

UST 195 D / 86° R0,8

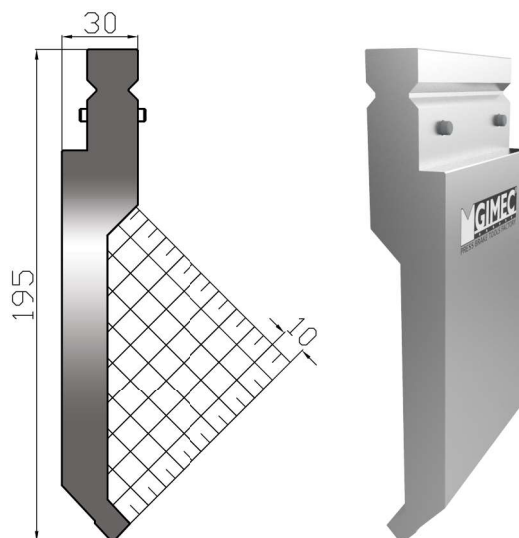

altezza height mm	angolo degree	raggio radius	acciaio steel	max kN/mt
195,0	86°	0,8	42CM4 T HRC 52+58	1000
lunghezze - lengths		mm 500 - fraz P 550		

UST 195 C / 60° R0,8

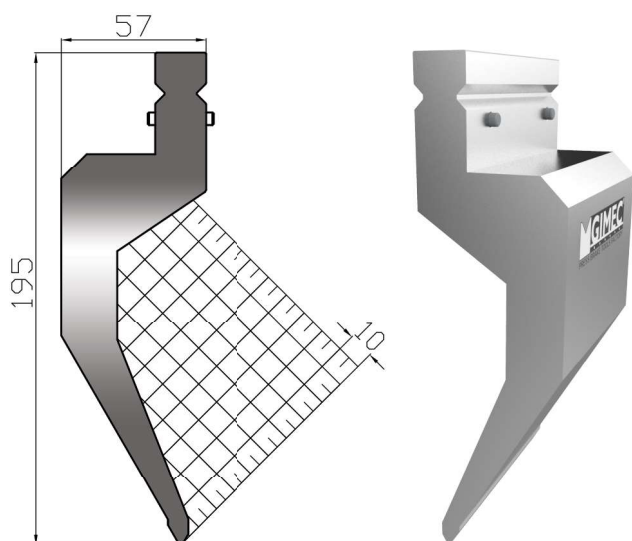

altezza height mm	angolo degree	raggio radius	acciaio steel	max kN/mt
195,0	60°	0,8	42CM4 T HRC 52+58	400
lunghezze - lengths		mm 500 - fraz P 550		

UST 195 C / 86° R0,8

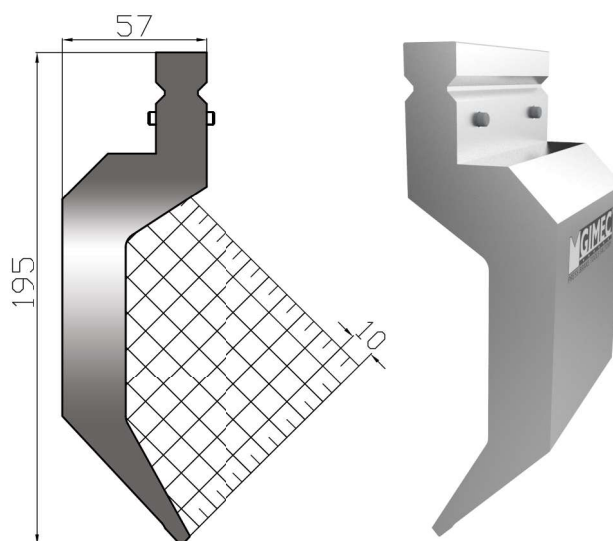

altezza height mm	angolo degree	raggio radius	acciaio steel	max kN/mt
195,0	86°	0,8	42CM4 T HRC 52+58	400
lunghezze - lengths		mm 500 - fraz P 550		

serie UST®

STANDARD TOOLS

UST 200 X / 28° R1,0

BIU-021

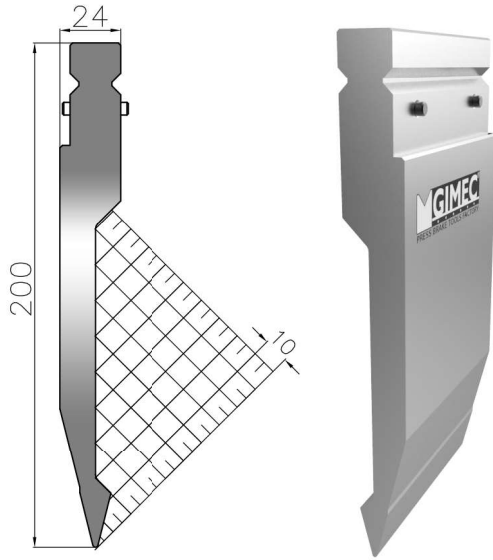

altezza height mm	angolo degree	raggio radius	acciaio steel	max kN/mt
200,0	28°	1,0	42CM4 T HRC 52+58	600
lunghezze - lengths			mm 515-fraz C250 - L550 (2)	

UST 200 D / 80° R1,0

BIU-022

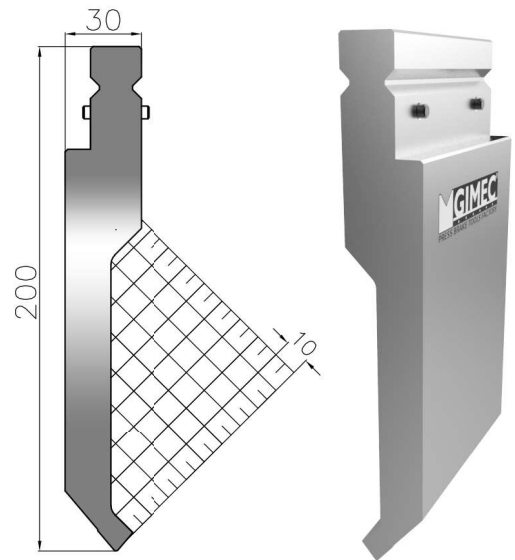

altezza height mm	angolo degree	raggio radius	acciaio steel	max kN/mt
200,0	80°	1,0	42CM4 T HRC 52+58	800
lunghezze - lengths			mm 515-fraz C250 - L550 (2)	

UST 200 C / 60° R1,0

STANDARD TOOLS

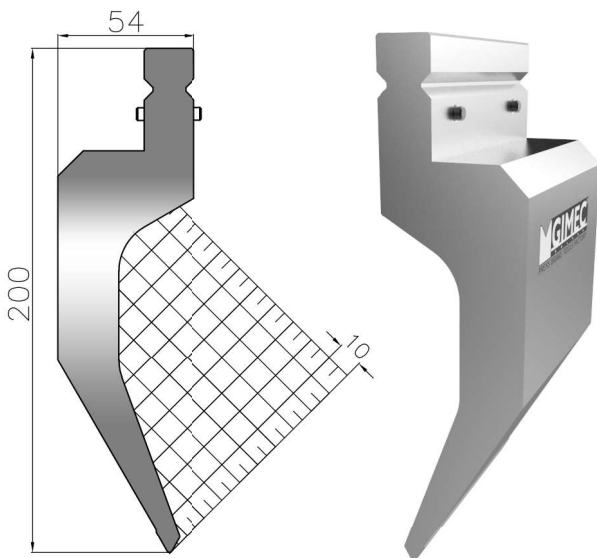

altezza height mm	angolo degree	raggio radius	acciaio steel	max kN/mt
200,0	60°	1,0	42CM4 T HRC 52+58	700
lunghezze - lengths			mm 500-fraz C250 - L550 (2)	

UST 200 C / 86° R1,0

BIU-023

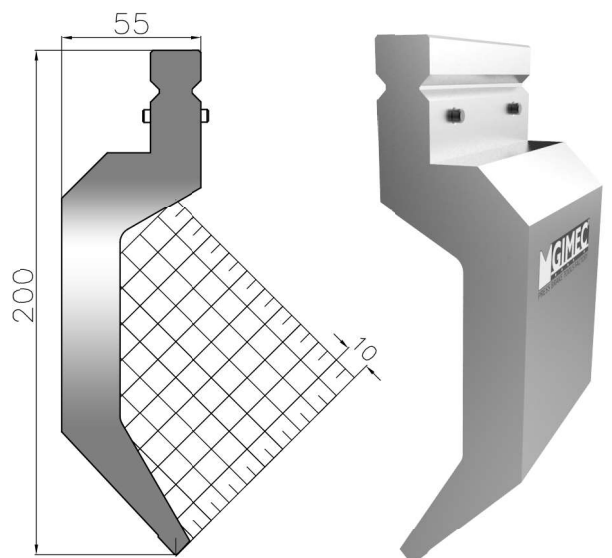

altezza height mm	angolo degree	raggio radius	acciaio steel	max kN/mt
200,0	86°	1,0	42CM4 T HRC 52+58	500
lunghezze - lengths			mm 515-fraz C250 - L550 (2)	

GIMEC URET

PELLICOLA ANTIGRAFFIO - DIE COVER FILM

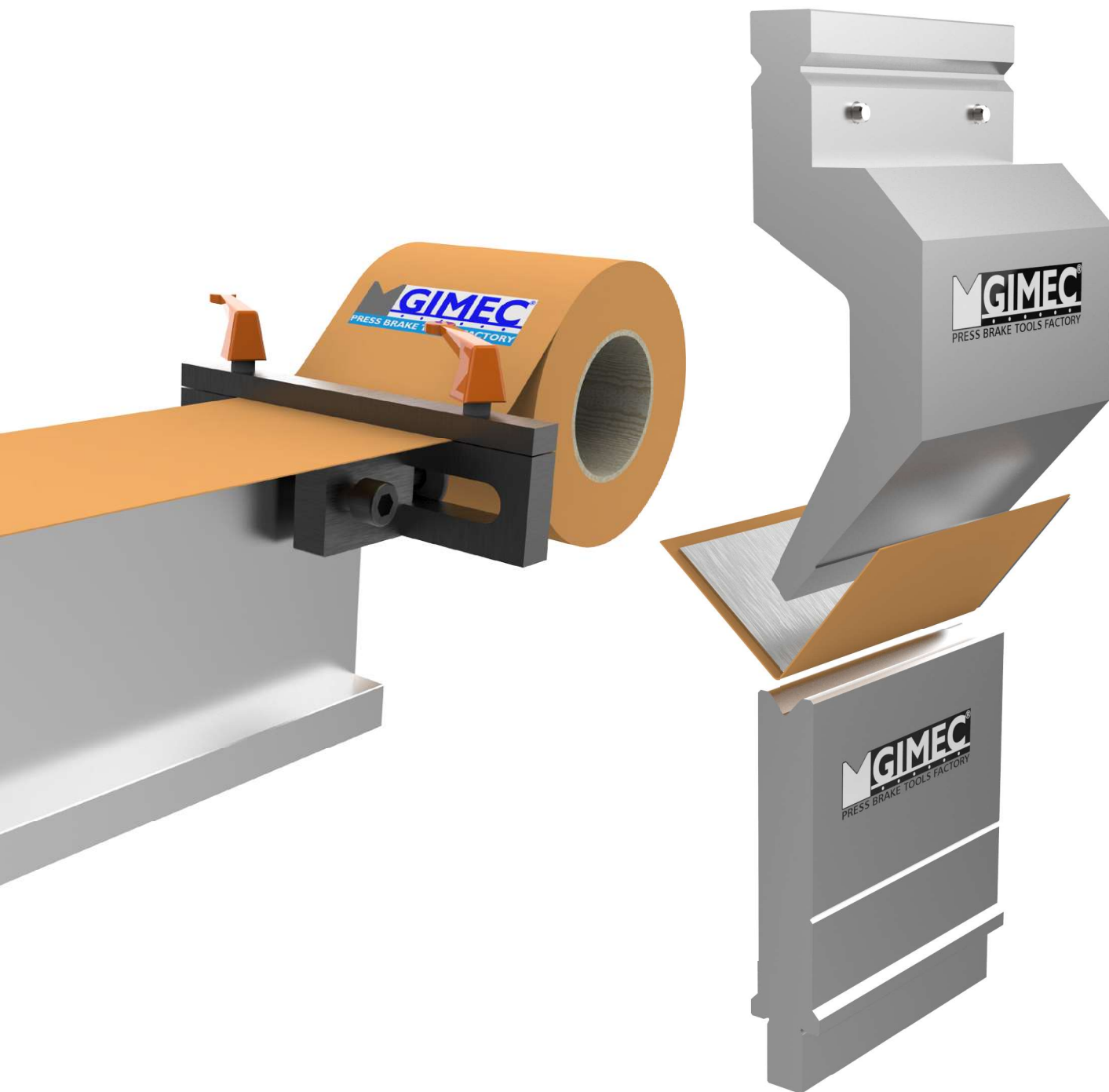

serie **UST**®

STANDARD TOOLS

Non troverete in nessun altro luogo una pellicola più tenace e duratura !!!

Nowhere else you can find a more strong and lasting film !!!

trovala a pagina - find it on page 98

serie UST®

STANDARD TOOLS

UST 237 S / 90° R1,2 BIU-036

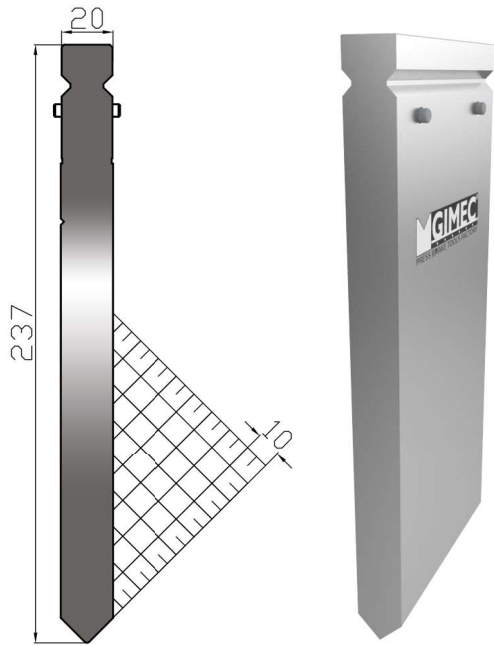

altezza height mm	angolo degree	raggio radius	acciaio steel	max kN/mt
237,0	90°	1,2	42CM4 T HRC 52+58	1000
lunghezze - lengths			mm 500-fraz C250 - L550 (2)	

UST 237 S / 60° R3,0 BIU-034

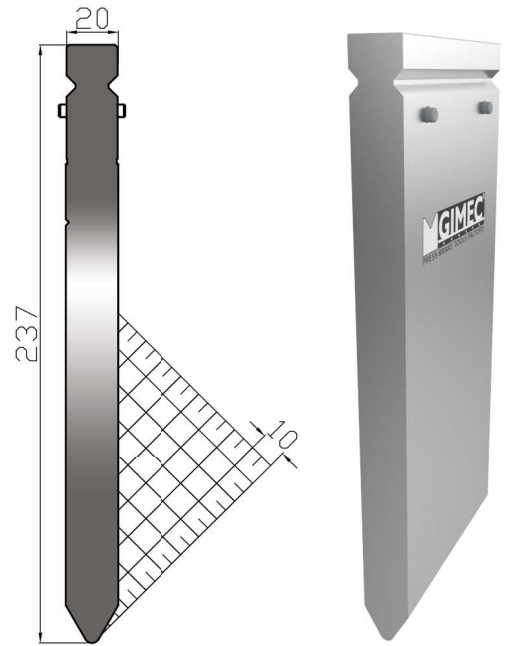

altezza height mm	angolo degree	raggio radius	acciaio steel	max kN/mt
237,0	60°	3,0	42CM4 T HRC 52+58	1300
lunghezze - lengths			mm 500-fraz C250 - L550 (2)	

UST 237 D / 90° R0,6 BIU-035

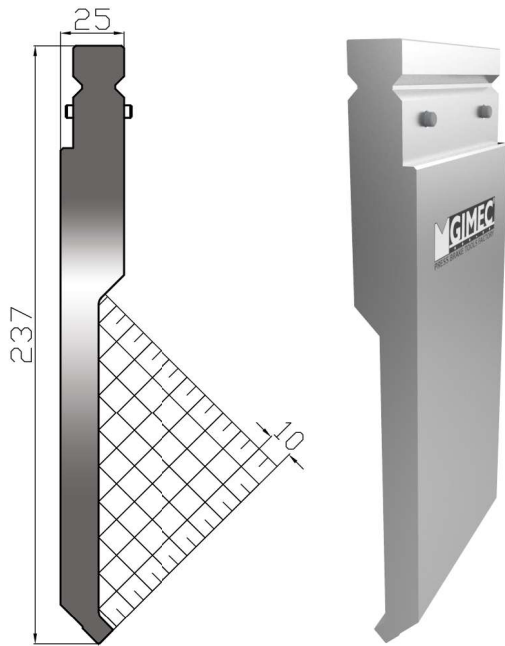

altezza height mm	angolo degree	raggio radius	acciaio steel	max kN/mt
237,0	90°	0,6	42CM4 T HRC 52+58	600
lunghezze - lengths			mm 500-fraz C250 - L550 (2)	

UST 237 X / 28° R1,0 BIU-031

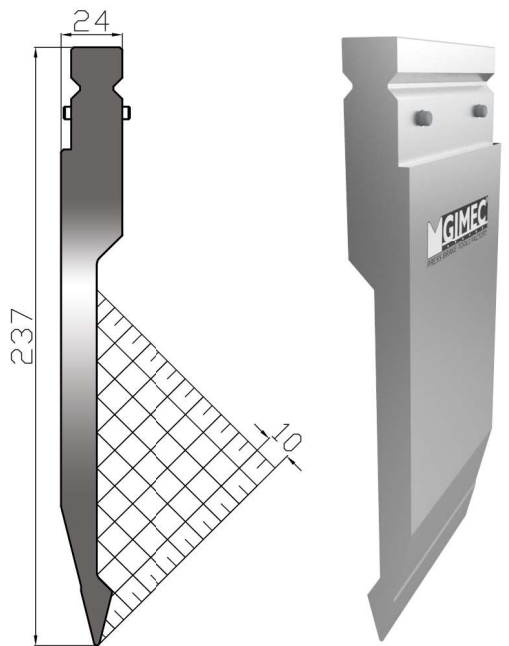

altezza height mm	angolo degree	raggio radius	acciaio steel	max kN/mt
237,0	28°	1,0	42CM4 T HRC 52+58	600
lunghezze - lengths			mm 500-fraz C250 - L550 (2)	

UST 237 D / 80° R1,0

BIU-032

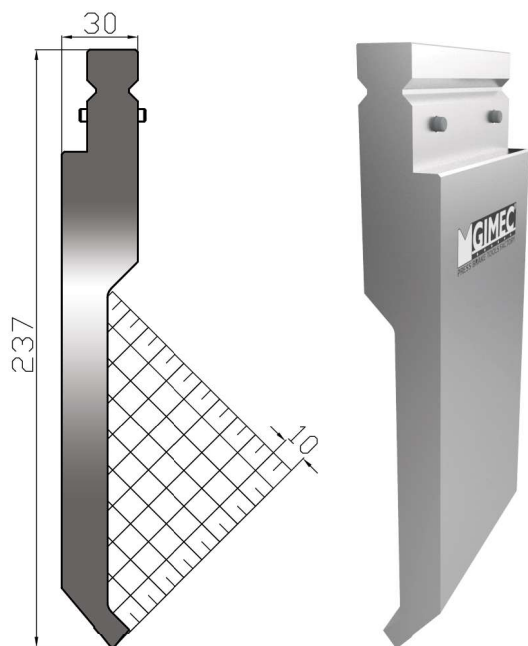

altezza height mm	angolo degree	raggio radius	acciaio steel	max kN/mt
237,0	80°	1,0	42CM4 T HRC 52+58	800
lunghezze - lengths		mm 500-fraz C250 - L550 (2)		

UST 237 C / 60° R1,0

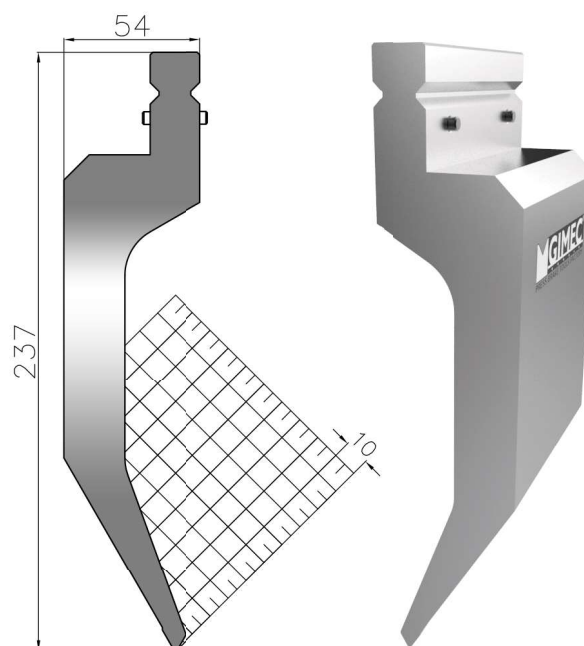

altezza height mm	angolo degree	raggio radius	acciaio steel	max kN/mt
237,0	60°	1,0	42CM4 T HRC 52+58	700
lunghezze - lengths		mm 500-fraz C250 - L550 (2)		

UST 237 C / 86° R1,0

BIU-033

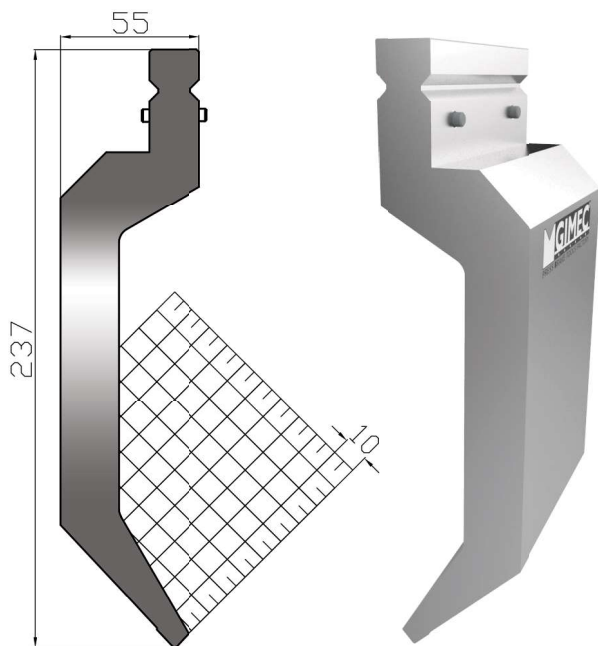

altezza height mm	angolo degree	raggio radius	acciaio steel	max kN/mt
237,0	86°	1,0	42CM4 T HRC 52+58	500
lunghezze - lengths		mm 500-fraz C250 - L550 (2)		



STANDARD TOOLS

serie **UST**®

UST 60° R4,0/S

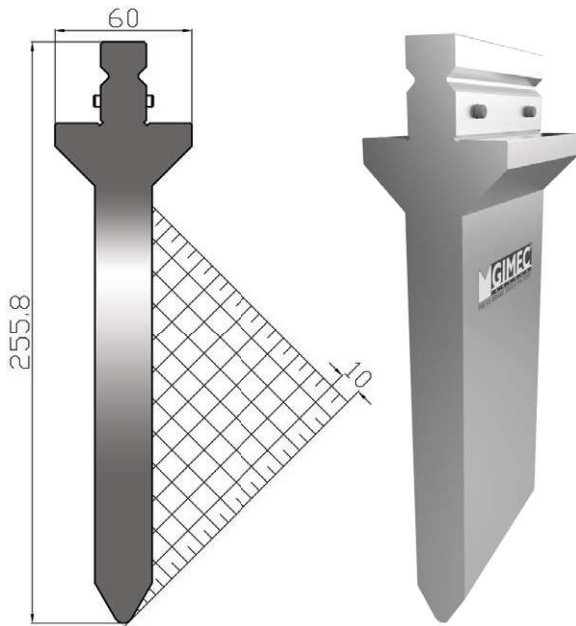

altezza height mm	angolo degree	raggio radius	acciaio steel	max kN/mt
255,8	60°	4,0	42CM4 T HRC 52+58	1300
lunghezze - lengths			mm 500-fraz C250 - L550 (1)	

UST 28° R1,0/S

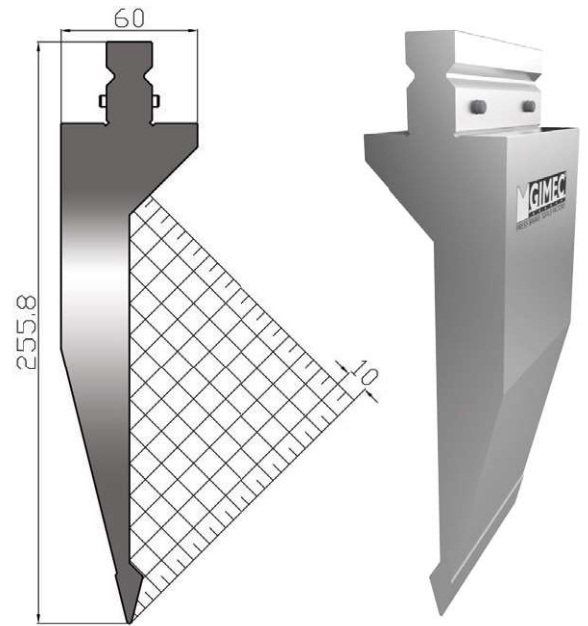

altezza height mm	angolo degree	raggio radius	acciaio steel	max kN/mt
255,8	28°	1,0	42CM4 T HRC 52+58	600
lunghezze - lengths			mm 500-fraz C250 - L550 (1)	

UST 86° R1,0/A

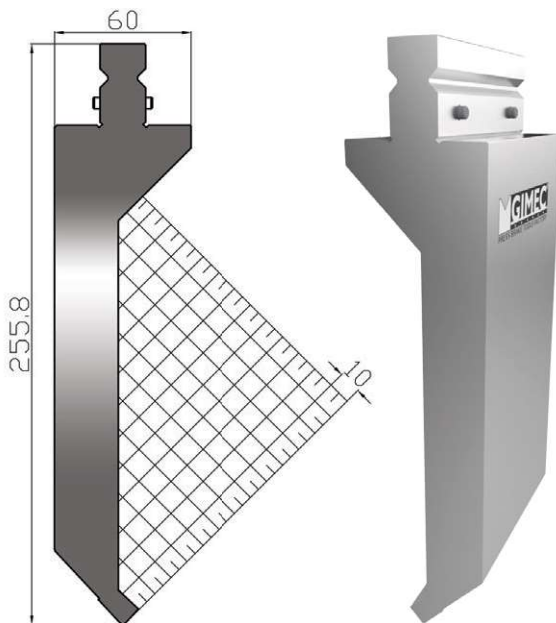

altezza height mm	angolo degree	raggio radius	acciaio steel	max kN/mt
255,8	86°	1,0	42CM4 T HRC 52+58	800
lunghezze - lengths			mm 500-fraz C250 - L550 (1)	

UST 86° R1,0/S

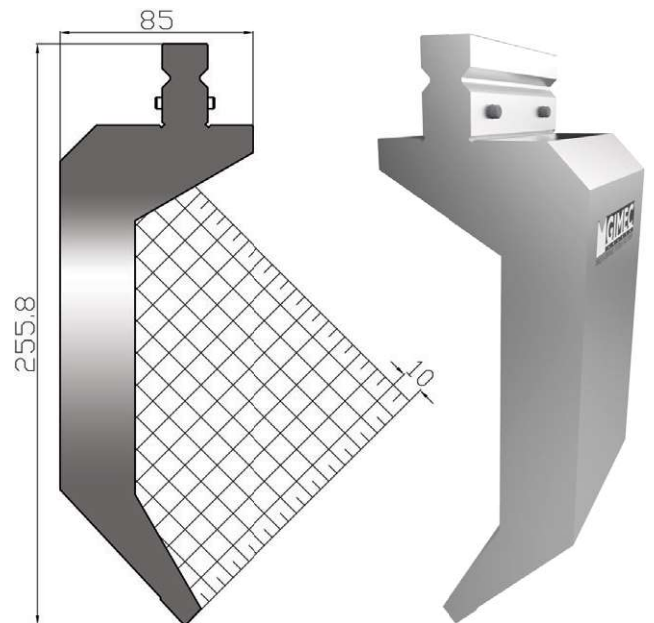

altezza height mm	angolo degree	raggio radius	acciaio steel	max kN/mt
255,8	86°	1,0	42CM4 T HRC 52+58	800
lunghezze - lengths			mm 500-fraz C250 - L550 (1)	

serie UST®

STANDARD TOOLS

UST 28° R1,0/SP

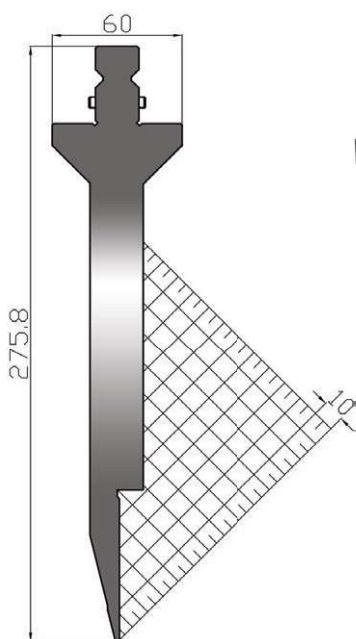

Gli utensili con peso inferiore a 12,5 kg vengono forniti con singolo o doppio pulsante.
 Oltre tale peso l'utensile viene fornito con spine.
 Tools with total weight inferior to 12,5 kg will be supplied with a single or double push button.
 Beyond such weight tool will be supplied with pins.

altezza height mm	angolo degree	raggio radius	acciaio steel	max kN/mt
275,8	28°	1,0	42CM4 T HRC 52+58	400
lunghezze - lengths			mm 500-fraz C250 - L550 (1)	

LUNGHEZZE • LENGTHS mm 500 - 515 - fraz C250 - L550 - P550

L mm	25	30	35	40	45	50	100L	100R	100	200	tot.pz/pcs
fraz C	250	2	1	1	1	1					7
fraz L (1)	550	2	1	1	1	1	1	1	1		10
fraz L (1A)	550	2	1	1	1	1	1	1	1		10
fraz L (2)	550	2	1	1	1	1	1	1	1		10
fraz P	550	2	1	1	1	1	1	1	1		10

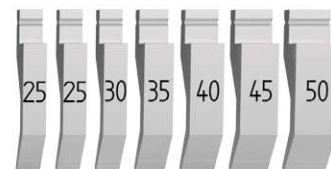

fraz C 250

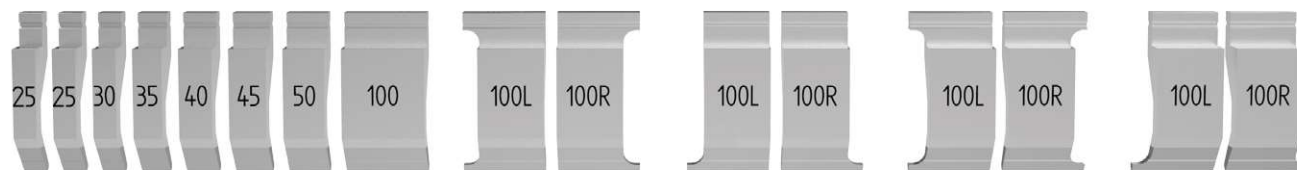

fraz 550

L(1)

L(1A)

L(2)

P

serie UST®

STANDARD TOOLS

UST 138 L 8

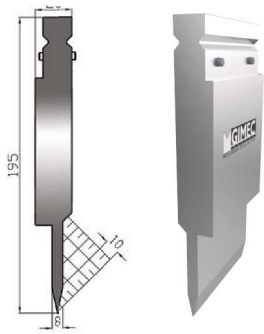

altezza height	angolo degree	raggio radius	max kN/mt
mm 195	24°	0,6	800
acciaio - steel			
lunghezze - lengths			

UST 138 M 8

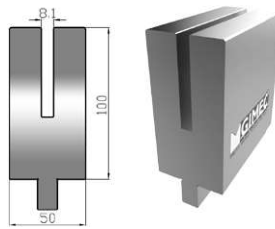

altezza height	V	raggio radius	max kN/mt
mm 100	mm 8	1,0	500
42CM4 T HRC52+58			
mm 500 - 550 fraz L			

UST 138 L 10

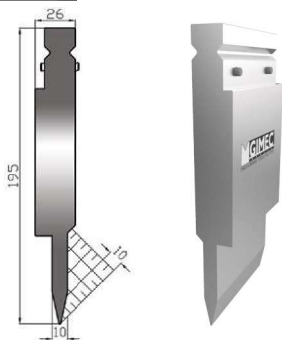

altezza height	angolo degree	raggio radius	max kN/mt
mm 195	24°	0,6	800
acciaio - steel			
lunghezze - lengths			

UST 138 M 10

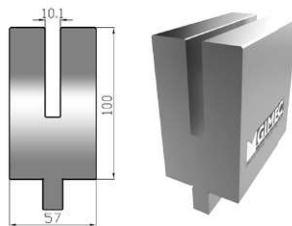

altezza height	V	raggio radius	max kN/mt
mm 100	mm10	1,0	500
42CM4 T HRC52+58			
mm 500 - 550 fraz L			

UST 138 L 12

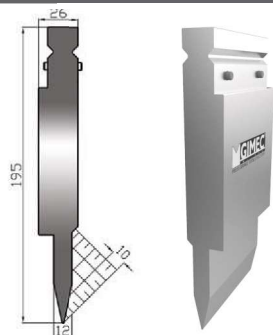

altezza height	angolo degree	raggio radius	max kN/mt
mm 195	24°	0,6	800
acciaio - steel			
lunghezze - lengths			

UST 138 M 12

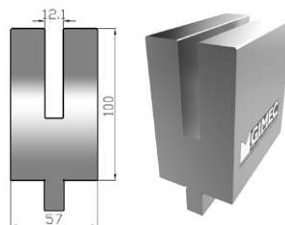

altezza height	V	raggio radius	max kN/mt
mm 100	mm12	1,0	500
42CM4 T HRC52+58			
mm 500 - 550 fraz L			



Si consiglia di utilizzare questi utensili su presse piegatrici sincronizzate in quanto occorre variare rapidamente la corsa della pressa tra la fase di piegatura e quella di schiacciatura. Non è possibile aumentare il raggio della matrice in quanto si potrebbero verificare deformazioni anomale della piega schiacciata.

We suggest to use these tools on synchronized press brakes as it is necessary to change quickly press stroke between bending and crushing position. It is not possible to increase lower tool radius because it would have some deformations on bend crushed.

UST 130

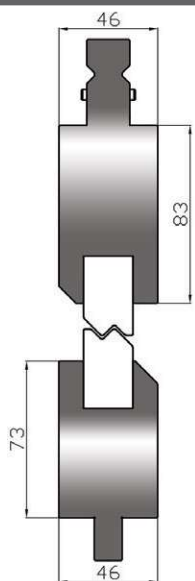

altezza height mm	acciaio steel	max kN/mt
73 + 83	C45	1000
lunghezze - lengths	mm 835 - 415	

US 131 Z 1 ÷ 15 mm

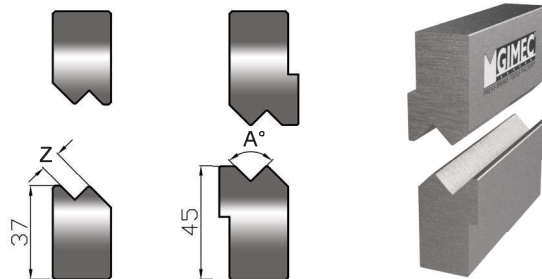

codice articolo item code	Z mm	A°	MAX sp./th.	codice articolo item code	Z mm	A°	MAX sp./th.
US 131 / 1,0	1,0	160°	0,5 mm	US 131 / 6,5	6,5	90°	1,5 mm
US 131 / 1,5	1,5	160°	0,6 mm	US 131 / 7,0	7,0	90°	2,0 mm
US 131 / 2,0	2,0	150°	0,8 mm	US 131 / 7,5	7,5	90°	2,0 mm
US 131 / 2,5	2,5	140°	1,0 mm	US 131 / 8	8	90°	2,5 mm
US 131 / 3,0	3,0	90°	1,0 mm	US 131 / 9	9	90°	2,5 mm
US 131 / 3,5	3,5	90°	1,2 mm	US 131 / 10	10	90°	3,0 mm
US 131 / 4,0	4,0	90°	1,2 mm	US 131 / 11	11	90°	3,0 mm
US 131 / 4,5	4,5	90°	1,5 mm	US 131 / 12	12	90°	3,0 mm
US 131 / 5,0	5,0	90°	1,5 mm	US 131 / 13	13	90°	3,0 mm
US 131 / 5,5	5,5	90°	1,5 mm	US 131 / 14	14	90°	3,0 mm
US 131 / 6,0	6,0	90°	1,5 mm	US 131 / 15	15	90°	3,0 mm
acciaio - steel				C45 T HRC 52+58			
lunghezze - lengths				mm 835 - 415			

UST 140

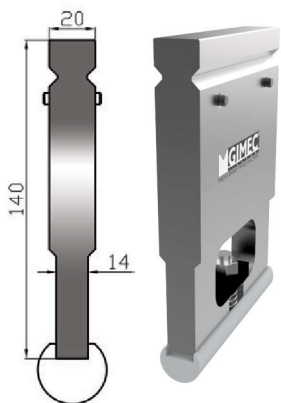

UST 256

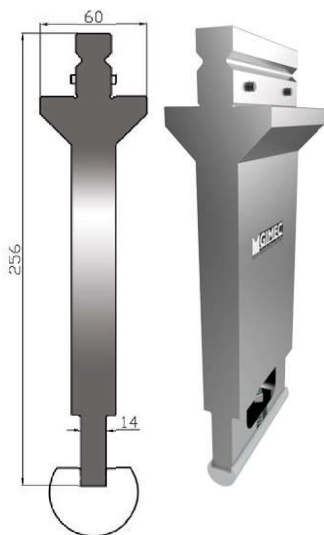

altezza height mm	140
raggio-radius MIN - MAX	8 ÷ 50 mm
acciaio steel	C45
lunghezze lengths	mm 830 - 412
max kN/mt	800

altezza height mm	256
raggio-radius MIN - MAX	8 ÷ 50 mm
acciaio steel	C45
lunghezze lengths	mm 830 - 412
max kN/mt	800

US 305 R 8 ÷ 50 mm

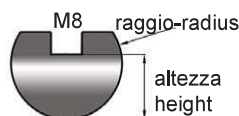

4 fori-holes mm 104-209...-104 = mm 835
2 fori-holes mm 103-209...-103 = mm 415



codice articolo item code	raggio radius	altezza height	codice articolo item code	raggio radius	altezza height
US 305/R 8	8	10 mm	US 305/R 25	25	29 mm
US 305/R 9	9	10 mm	US 305/R 27,5	27,5	34 mm
US 305/R 10	10	12 mm	US 305/R 30	30	34 mm
US 305/R 12,5	12,5	17 mm	US 305/R 35	35	45 mm
US 305/R 15	15	20 mm	US 305/R 40	40	44 mm
US 305/R 17,5	17,5	22 mm	US 305/R 45	45	50 mm
US 305/R 20	20	24 mm	US 305/R 50	50	54 mm
US 305/R 22,5	22,5	25 mm			
acciaio - steel			C45 - 39NCM3 nitruato (N)		
lunghezze - lengths			mm 835 - 415		

US 310

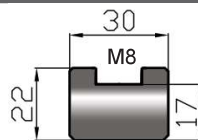

4 fori-holes mm 104-209...-104 = mm 835
2 fori-holes mm 103-209...-103 = mm 415



codice articolo item code	acciaio steel
US 310	C45
US 310 T	C45 T HRC 52+58
lunghezze - lengths	mm 835 - 415

serie **UST**®

STANDARD TOOLS